

南京大學

工程管理学院



# 自动化导论

## Automation: An Introduction

南京大学控制科学与智能工程系  
陈春林

Email: [clchen@nju.edu.cn](mailto:clchen@nju.edu.cn)

2025年3月4日

# 1 绪论——自动化的历史与未来

## 1.1 自动控制发展简史

## 1.2 自动控制主要研究领域

## 1.3 一个小例子：倒立摆

---

# 1.1 自动控制发展简史

(1) 控制的概念和思想由来已久  
(1900年以前)

---

(0)中国，埃及和巴比伦出现**自动计时漏壶**  
(1400B.C. ~1100B.C.)。孙武著《孙子兵法》  
(600B.C.)

西汉漏壶



(1)秦昭王时，**李冰**主持修筑**都江堰**体现的系统观念和  
(300B.C.)

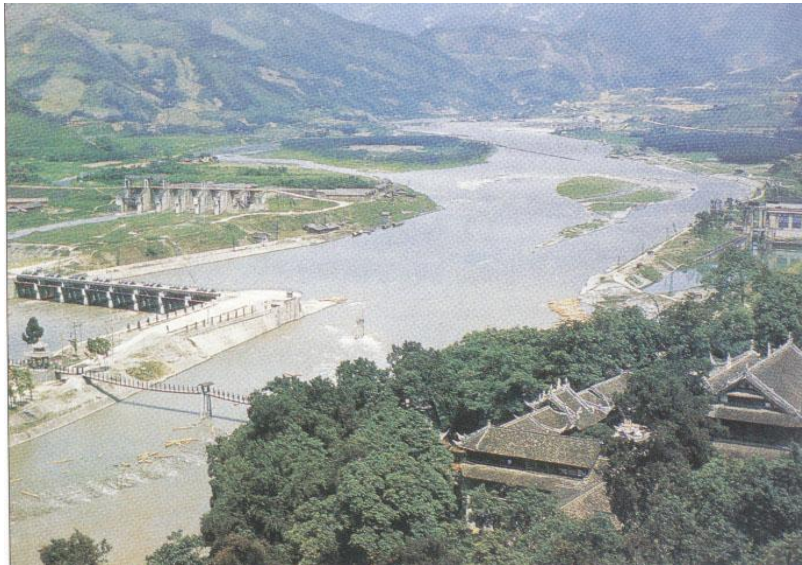

(2) 亚历山大的希罗发明开闭庙门和分发圣水等自动装置(100年)

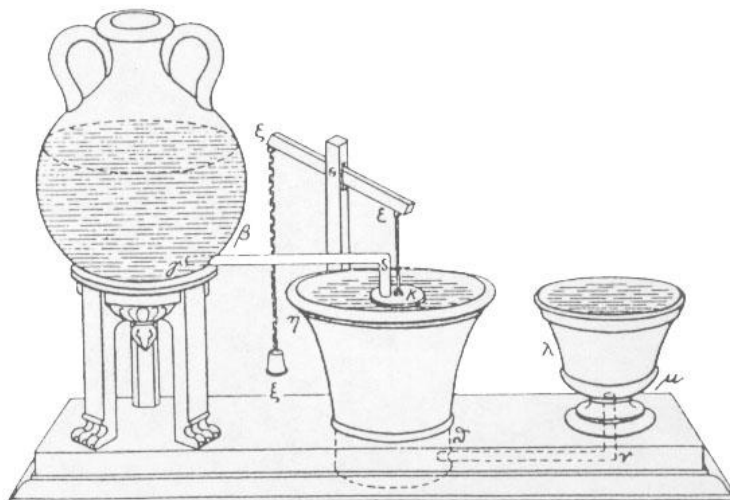

(3) 中国张衡发明水运浑象，研制出自动测量地震的候风地动仪  
(东汉, 132年)



(4) 中国马钧研制出齿轮传动的自动指示方向的指南车(三国,235年)



指南车 (1)模型

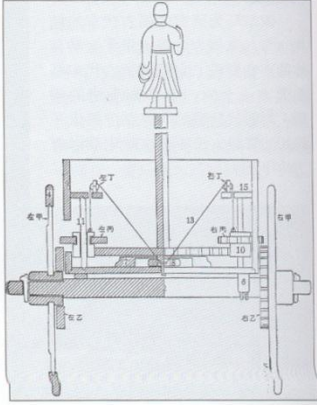

(2)结构图

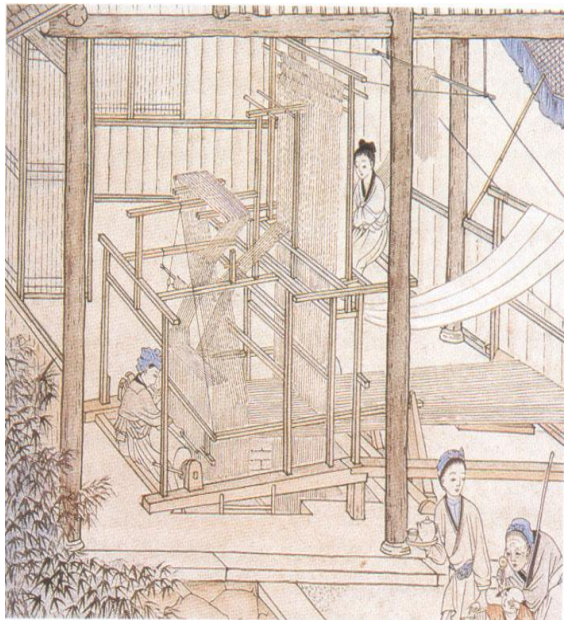

(5) 中国明代宋应星所著《天工开物》记载有程序控制思想(CNC)的提花织机结构图(1637年)

(6) 英国 J. Watt 用离心式调速器控制蒸汽机的速度(1788年)

(7) 英国 J. C. Maxwell 发表 “论调速器” (On Governors) 论文(1868年)

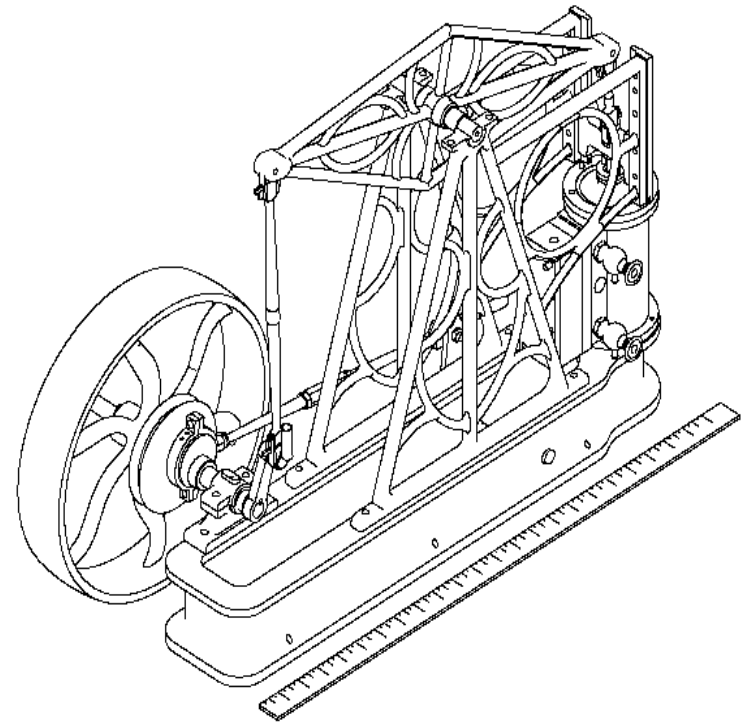
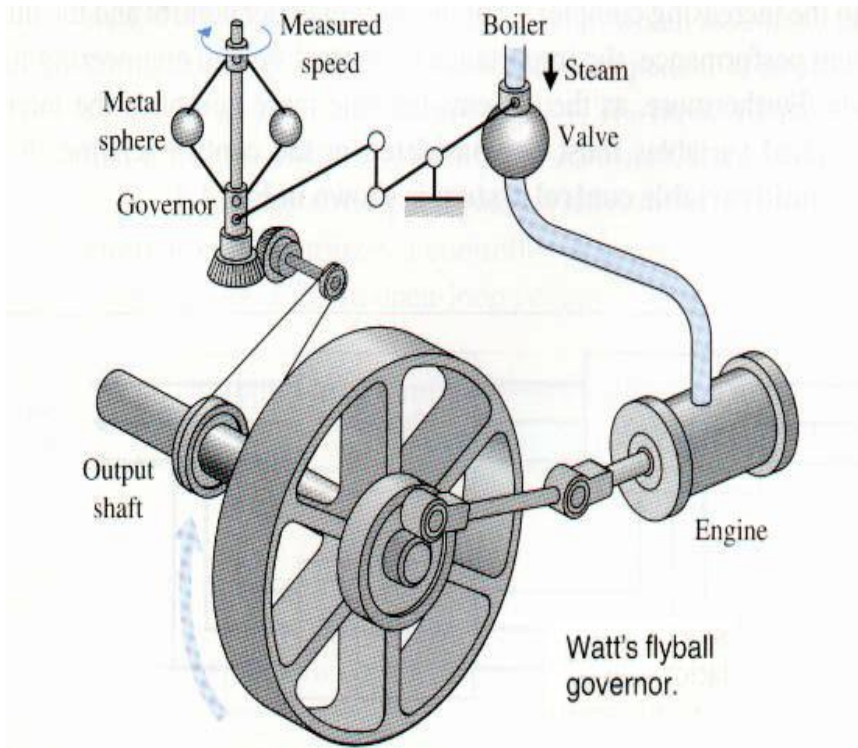

(8) 英国E.J. Routh建立Routh判据(Routh-Hurwitz Stability Criteria) (1875年)

(9) 俄国A.M. Lyapunov博士论文“论运动稳定性的一般问题” (1892年)

(10) 英国J. M. Gray设计出第一艘全自动蒸汽轮船“东方”号 (Great Eastern) (1866年)

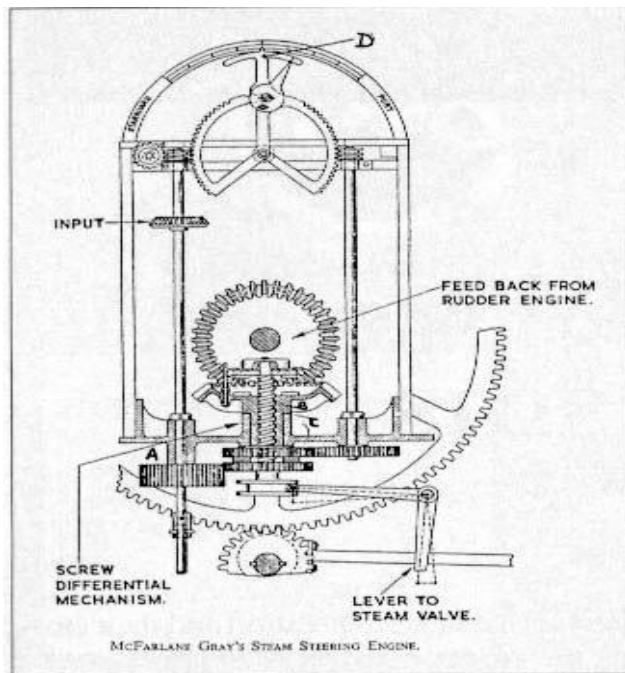

*McFarlane Gray's steam steering engine (reproduced from Proceedings Institution of Mechanical Engineers).*



(11)由徐寿设计的中国第一艘蒸汽轮船“黄鹄”号(L20m, 25T, 10km/hr)在安庆内军械所下水(1866)。次年,中国第一艘木质明轮蒸汽舰船“恬古”号在江南造船厂下水。



徐 寿

操江号(62mx10m), 392匹  
马力, 600T排水, 备炮9门

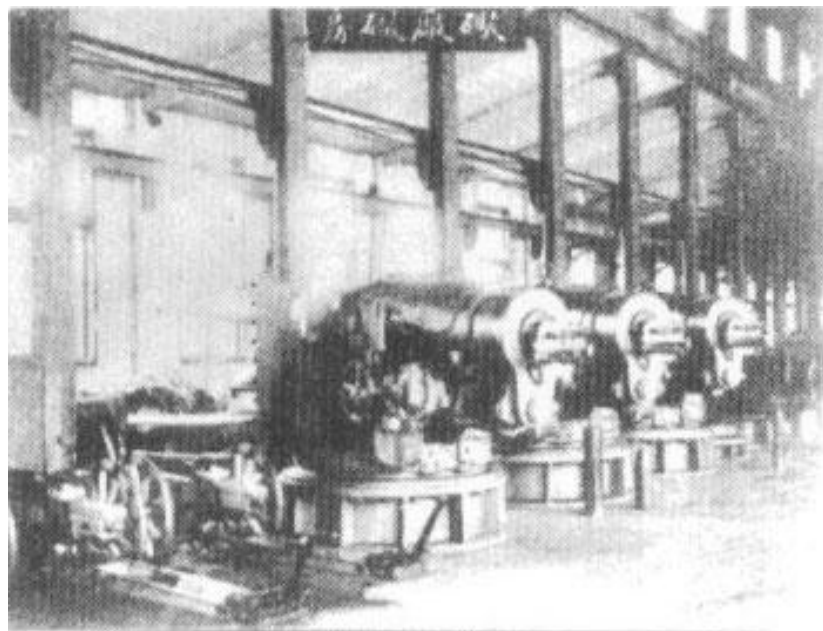

江南制造总局炮厂厂房

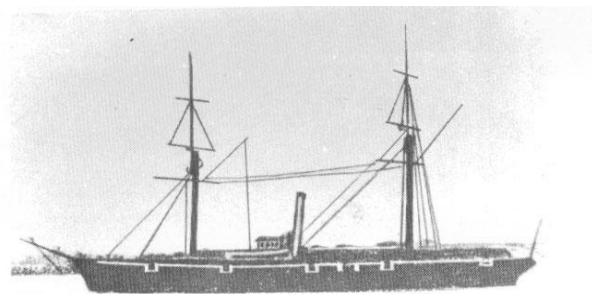

“操江”号螺轮蒸汽兵轮船

## (2) 自动控制理论的发展和现状

1. 经典控制理论
    - 线性控制理论
    - 非线性控制理论
    - 采样控制理论
  2. 现代控制理论
  3. 大系统理论
  4. 智能控制理论
-

## 经典控制前期 (The Pre-classical Period) (1900–1935)

(1) 美国福特(Ford Motor)汽车公司  
建成最早的汽车装配流水线(1913)

(2) 美国N. Minorsky研制出用于船舶驾驶的伺服结构，提出PID控制方法(1922)



(3) 美国MIT的Vannevar Bush研制成第一台大型模拟计算机 (Differential Analyzer)(1928)

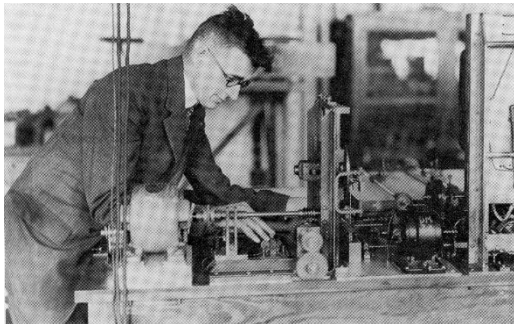

V. Bush

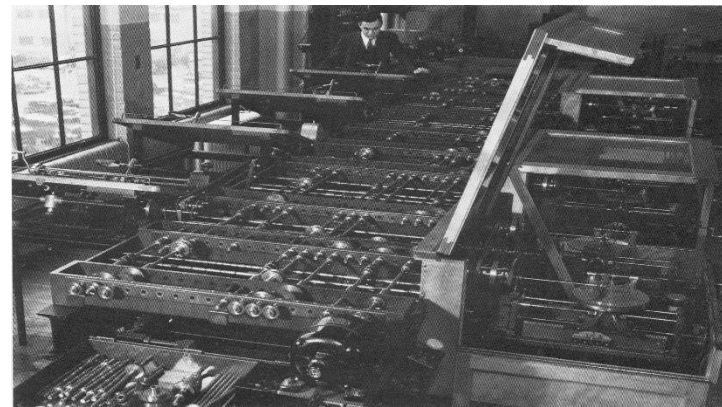

## (4) 美国 H.S. Black 提出放大器性能的负反馈方法 (Negative Feedback Amplifier) (1927)

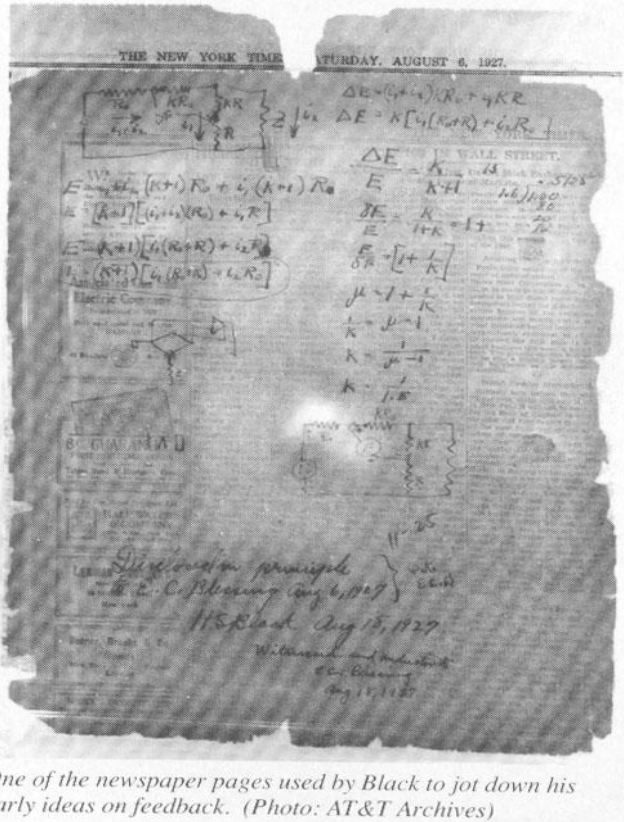

One of the newspaper pages used by Black to jot down his early ideas on feedback. (Photo: AT&T Archives)



H. S. Black

# (5) 美国 E. Sperry 以及 C. Mason 研制出火炮控制器 (1925), 气压反馈控制器 (1929)

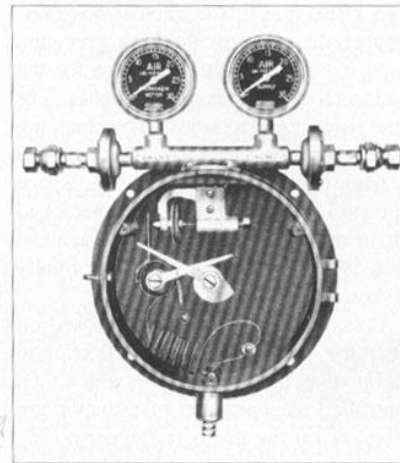
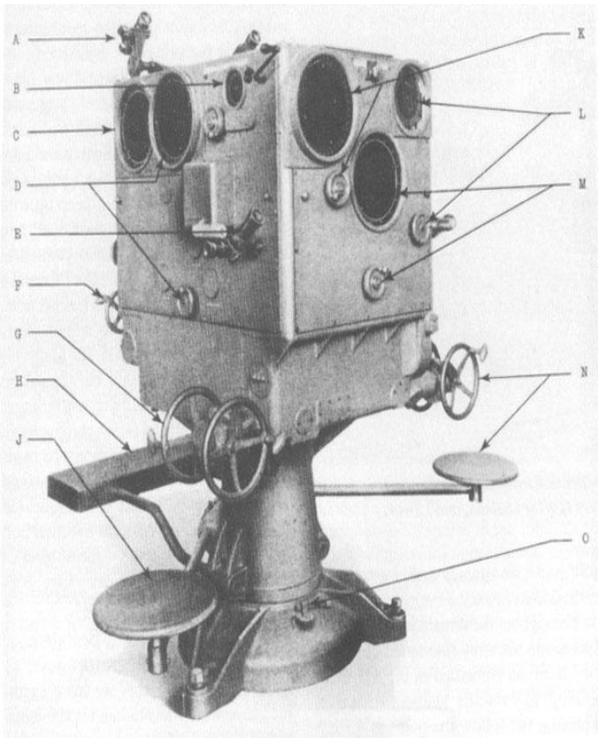

Fig. A simple Foxboro Company pneumatic controller. The controller was introduced in about 1922.

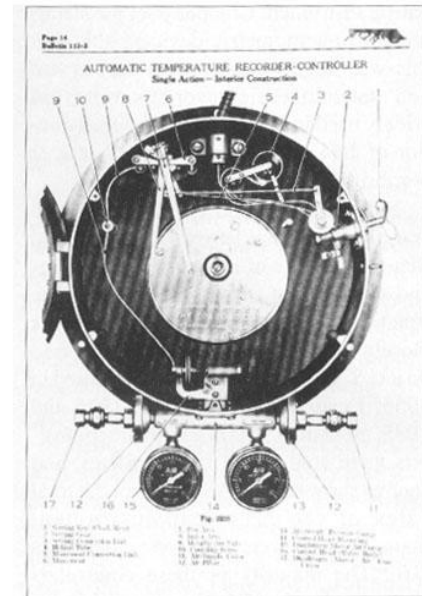

Fig. A Foxboro Company pneumatic recorder-controller of about 1929,

# 经典控制 (Classical Control) (1935–1950)

★(1) 美国贝尔实验室的H. Bode(1938), 以及Nyquist(1940)提出频率响应法

(2) 美国Taylor仪器公司的J. G. Ziegler和N. B. Nichols提出PID参数的最佳调整法(1942)



N.B.  
Nichols

★(3) 美国MIT的N. Wiener研究随机过程的预测(1942), 提出Wiener滤波理论(1942), 发表《控制论》(Cybernetics)一书(1948), 标志着控制论学科的诞生。

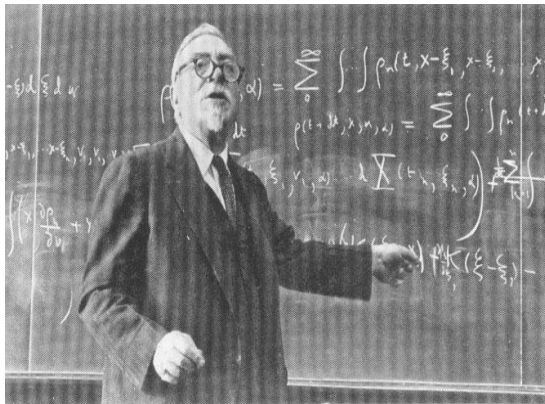

N. Wiener

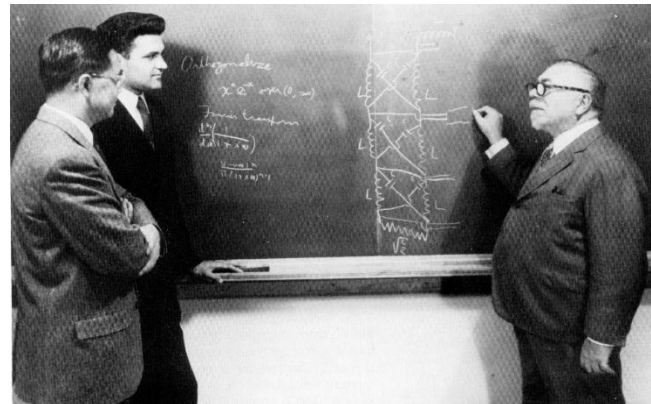

N. Wiener, shown here in 1954 with Yuk Wing Lee (left) and Amar G. Bose, discussing an aspect of statistical communication theory

(4) 美国的H. Hazen发表“关于伺服结构理论” (Theory of Servomechanism) (1934), 并在MIT建立伺服机构实验室 (Servomechanism Laboratory) (1939)



H. Hazen

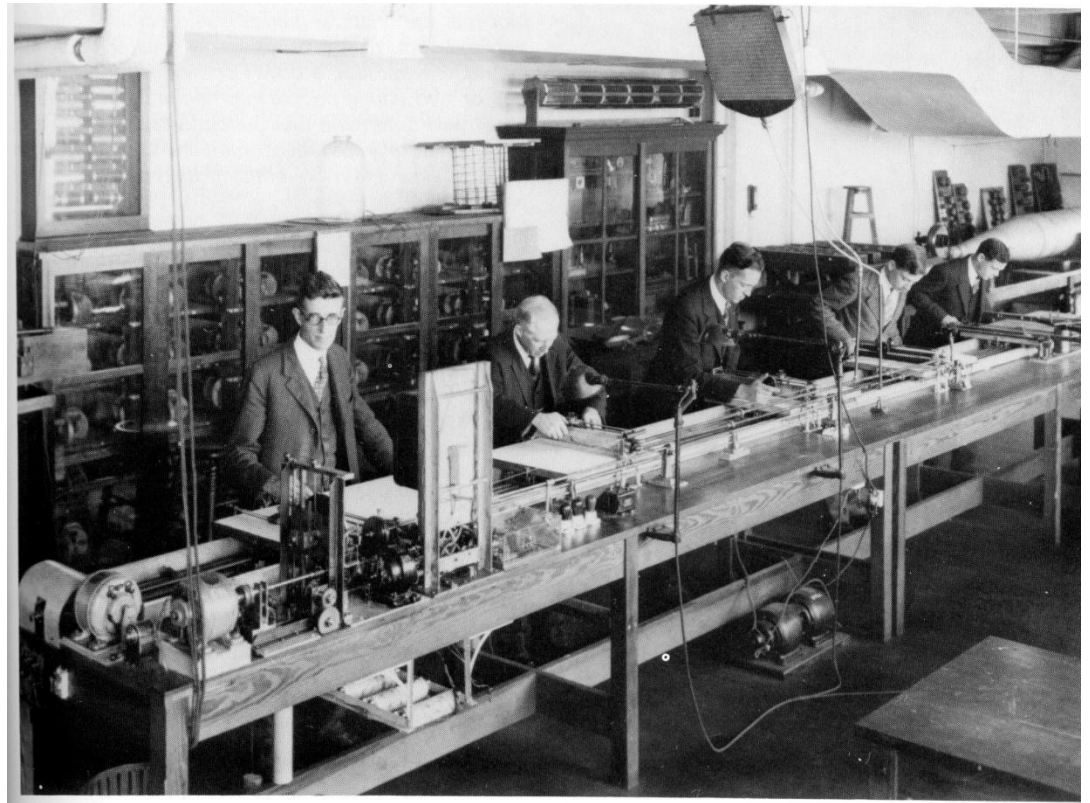

(5) 英国A. M. Turine提出图灵计算机的设想(1937)

(6) 在贝尔实验室Bode领导的火炮控制系统研究小组工作的C. Shannon提出继电器逻辑自动化理论(1938), 随后, 发表专著《通信的数字理论》(The Mathematical Theory of Communication), 奠定了**信息论**的基础(1948)

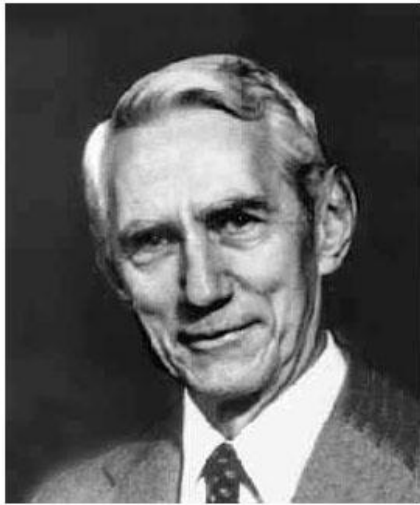

C. E. Shannon

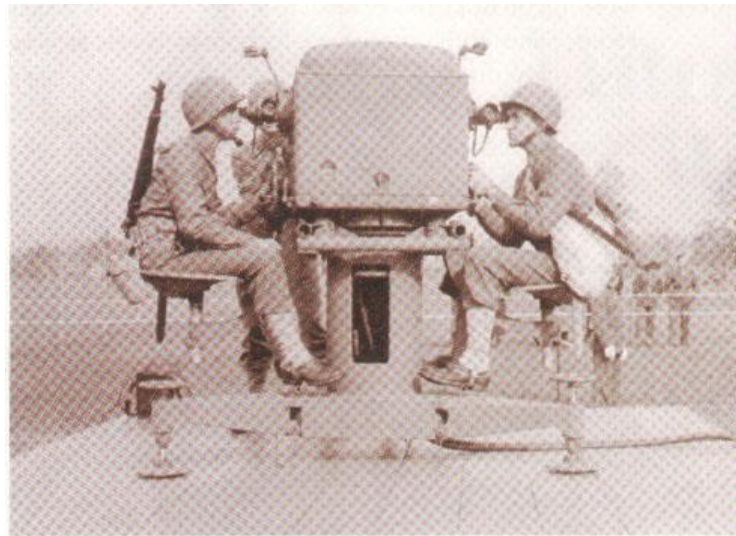

The tracker of the M-9 electrical gun director in action. As one soldier orients the telescopes in elevation, the other orients them in azimuth by turning the entire tracker head.

(7) MIT Radiation Laboratory在研究SCR-584雷达控制系统的过程中，创立了Nichols Chart Design Method, R. S. Philips的工作 On Noise in Servomechanisms, 以及 Hurwicz (1947)的数字控制系统(Sampled Data System)

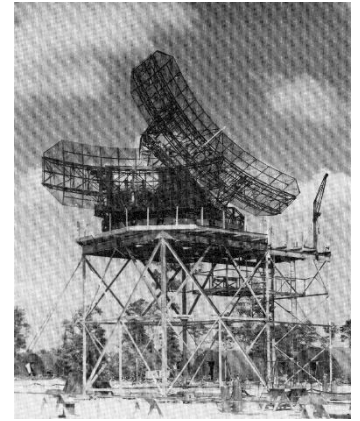

★ (8) 美国W. Evans提出根轨迹法(Root Locus Method) (1948), 以单输入线性系统为对象的经典控制研究工作完成。

(9) 多本有关经典控制的经典名著相继出版, 包括

Ed. S. Smith的Automatic Control Engineering (1942),

H. Bode的Network Analysis and Feedback Amplifier(1945),

L.A. MacColl的Fundamental Theory of Servomechanisms (1945), 以及钱学森的《工程控制论》(Engineering Cybernetics) (1954)

---

# 现代控制 (Modern Control) (1950- )

二次世界大战中火炮，雷达，飞机以及通讯系统的控制研究直接推动了经典控制的发展。五十年代后兴起的现代控制起源于冷战时期的军备竞赛，如导弹(发射，操纵，指导及跟踪)，卫星，航天器和星球大战，以及计算机技术的出现。



(1) 苏联L.S. Pontryagin发表“最优过程数学理论”，提出极大值原理(Maximum Principle)(1956)

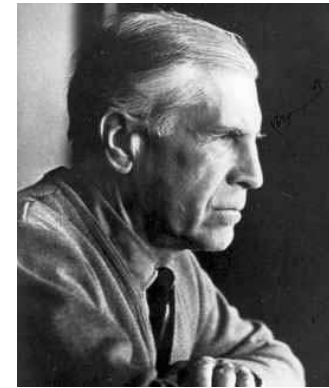

L.S. Pontryagin

(2) 美国R. Bellman在RAND Coporation数学部的支持下，发表著名的Dynamic Programming，建立最优控制的基础(1957)



McDonnell F4 phantom aircraft with two General Electric J-79 turbojet engines.



Hawk ground-to-air missile (courtesy of the Raytheon Co.).

(3) 国际自动控制联合会(IFAC)成立(1957)，中国为发起国之一，第一届学术会议于莫斯科召开(1960)

## (4) 美国MIT的Servomechanism Laboratory研制出第一台数控机床(1952)

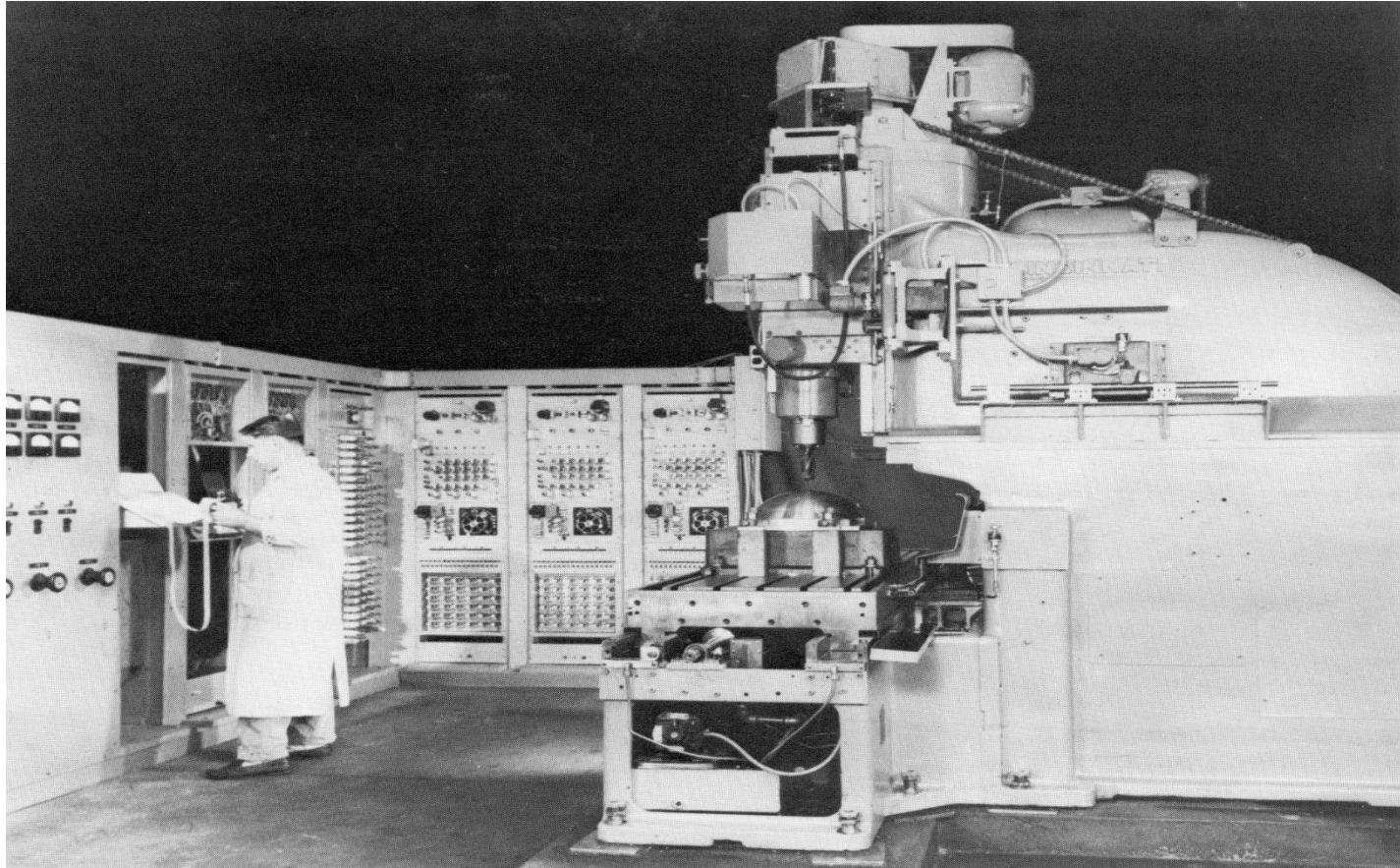

## (5) 世界第一颗人造地球卫星(Sputnik)由苏联发射成功 (1957)

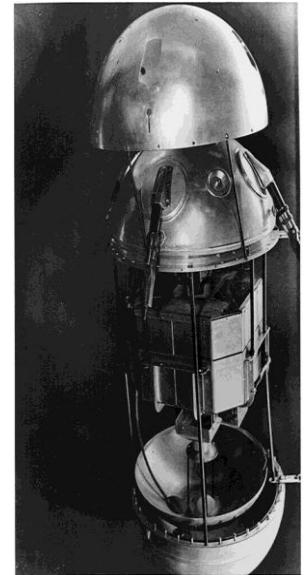
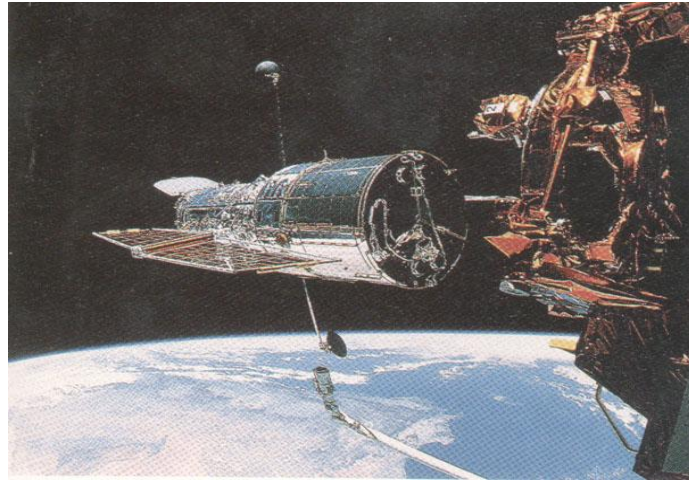
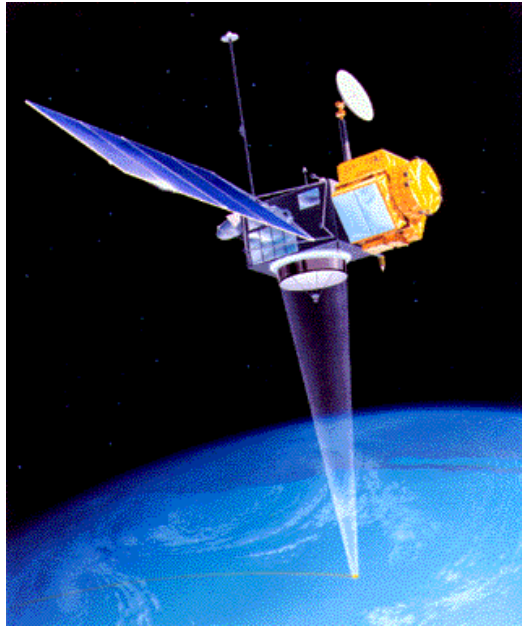

1957. Laika. Sputnik 2

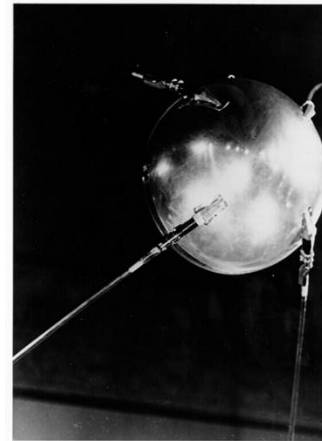

Sputnik 1 was the first artificial satellite launched into space

(6) 美国 George Devol 研制出第一台工业机器人样机(1954), 两年后, 被称为机器人之父的 Joseph Engelberger 创立了第一家机器人公司, Unimation



★ (7) 美籍匈牙利人 R. E. Kalman 发表 “On the General Theory of Control Systems” 等论文, 引入状态空间法分析系统, 提出能控性, 能观测性, 最佳调节器和 Kalman 滤波等概念, 奠定了现代控制理论的基础(1960)

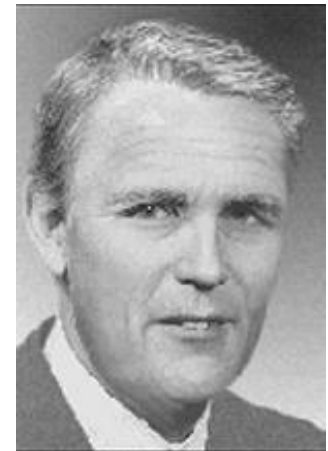

R.E. Kalman

## (8) 苏联东方-1号飞船载着加加林进入人造地球卫星轨道，人类宇航时代开始了(1961)

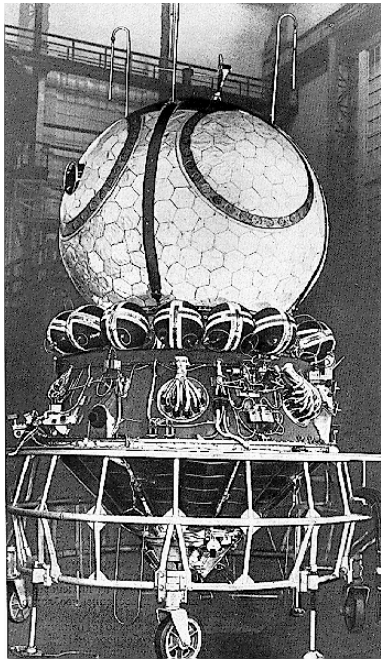

Capsule used in first manned orbit of earth



In 1961, the first human to pilot a spacecraft, Yuri Gagarin, was launched by the Soviet Union aboard Vostok I.



1961, at the age of 27, Gagarin left the earth. It was April the 12th, 9.07 Moscow time (launch-site, Baikonur). 108 minutes later, he was back. The period of orbital revolution was 89:34 minutes (this figure was "calculated by electronic computers"). The missions maximum flight altitude was 327 000 meters. The maximum speed reached was 28 260 kilometers per hour.



A stamp issued by Russia to memorize Y. Gagarin

**(9) 1963年, 美国的Lofti Zadeh与C. Desoer发表Linear Systems - A State Space Approach。1965年, Zadeh提出模糊集合和模糊控制概念**

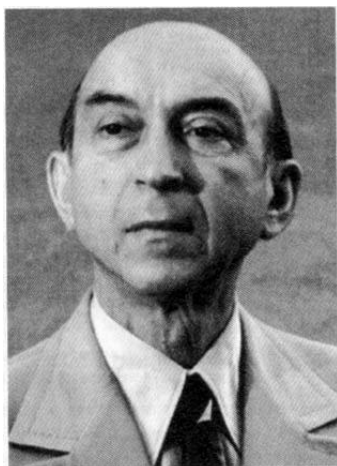

Lotfi A. Zadeh



C. Desoer



**(10) 美国的E.I. Jury 发表“数字控制系统” (Sampled-Data Control System), 建立了数字控制及数字信号处理的基础 (1958)**

---

**(11) 苏联发射“月球”9号探测器，首次在月面软着陆成功(1966)，三年后(1969)，美国“阿波罗”11号把宇航员N. A. Armstrong送上月球。**

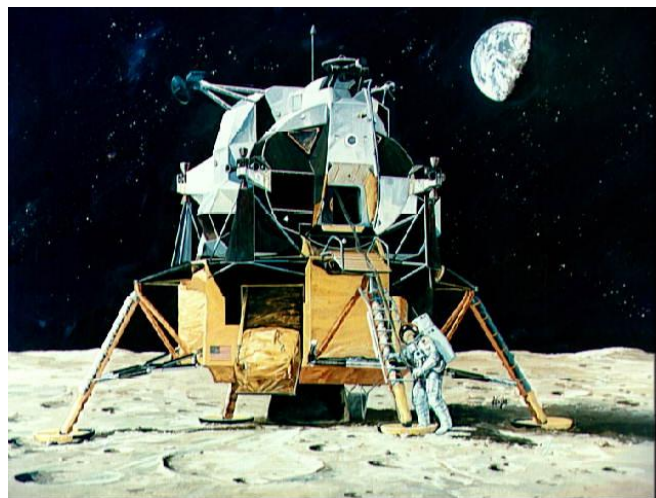

N.A. Armstrong

**(12) 瑞典Karl J. Astrom提出最小二乘辨识，解决了线性定常系统参数估计问题和定阶方法(1967)，六年后，提出了自启调节器，建立自适应控制的基础。Astrom于1993年获得IEEE Medal of Honor。**

**★(13) 英国H.H Rosenbrock 发表State Space and Multivariable Theory(1970)。加拿大W.M Wonham 发表Linear Multivariable Control: A Geometric Approach(1974)。**



K. J. Astrom



W.M Wonham

# 大系统理论 (Large Scale System) (1970- )

## (1) 美国的M. E. Merchant提出计算机集成制造的概念(1969)

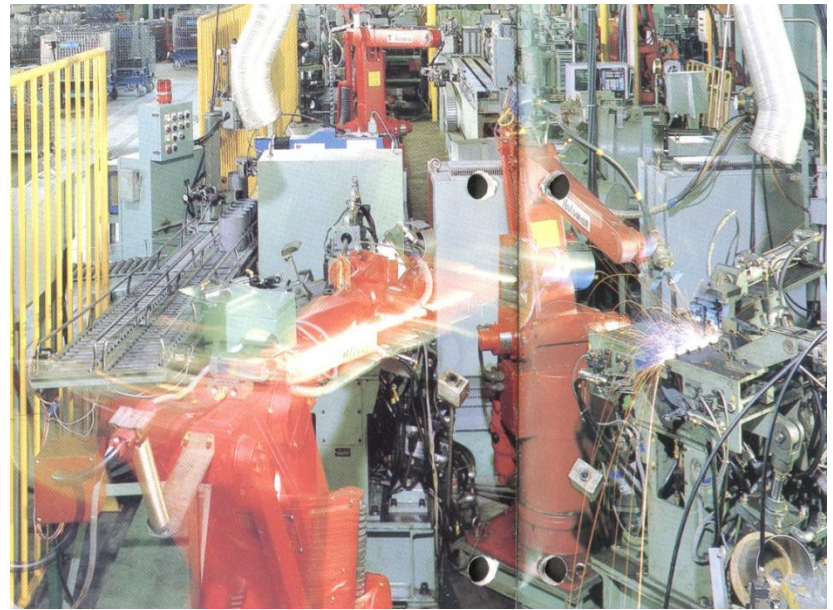
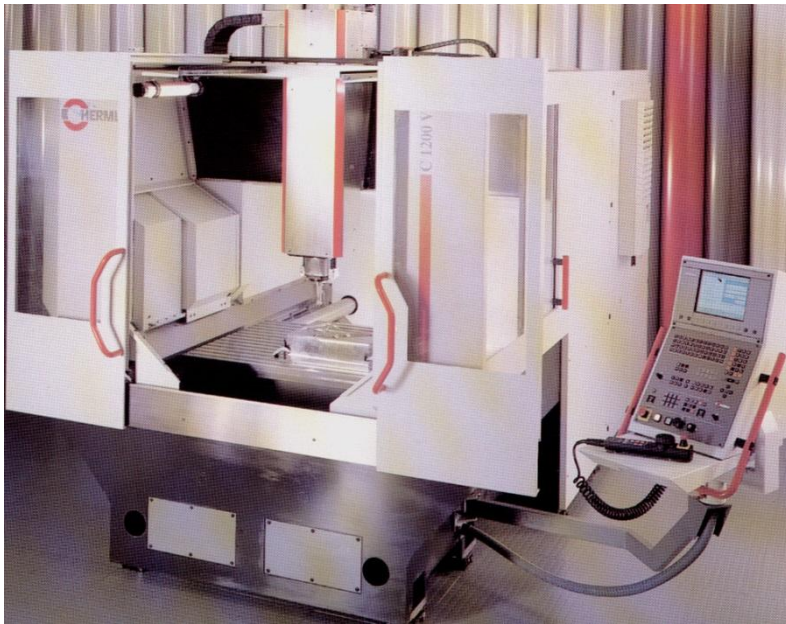

## (2) 美国ARPA计算机网络初步建成(1971)

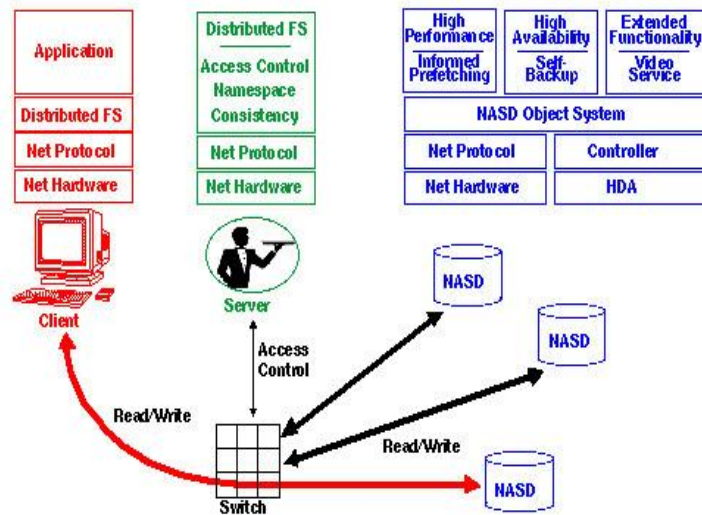

## (3) 日本Fanuc公司研制出由加工中心和工业机器人组成的柔性制造单元 (1976)

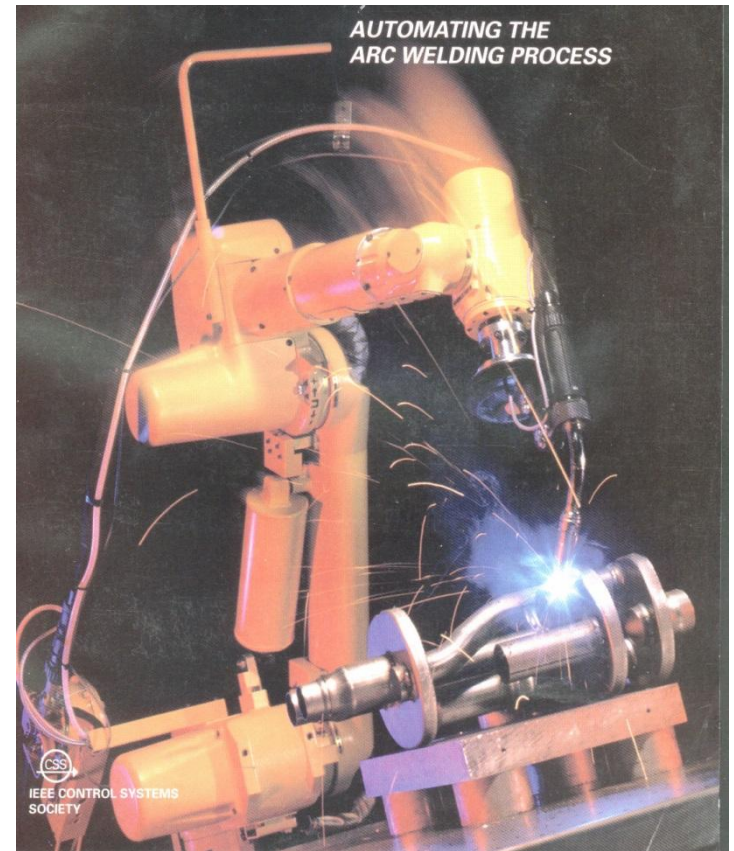

**(4) 美国R. Brockett提出用微分几何研究非线性控制系统(1976), 意大利A. Isidori出版(Nonlinear Control Systems) (1985)。**



*From left to right, the participants of the special invited session on History of Control at the 34th CDC: S. Shahruz (session co-organizer), Irena Lasiecka, Karl Åström, Art Krener, Irwin Sandberg, Roger Brockett, Tom Kailath, and Linda Bushnell (session co-organizer).*



R. Brockett



A. Isidori

(5) 加拿大G. Zames提出H<sub>∞</sub>鲁棒控制设计方法(1981年)

Gorge Zames



(6) 美国“哥伦比亚”号航天飞机首次发射成功(1981年)



**(7) 美国A. Bryson 和Y.C Ho 发表Applied Optimal Control(1969)。  
Y.C Ho 和X.R Cao等提出离散事件系统理论(1983)**

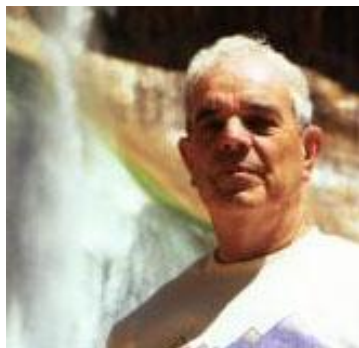

A. Bryson



Yu C. Ho (何毓琦)



X.R.Cao (曹希仁)

**(8) 中国批准863高技术计划，包括自动化领域的计算机集成制造系统和智能机器人两个主题(1986)**

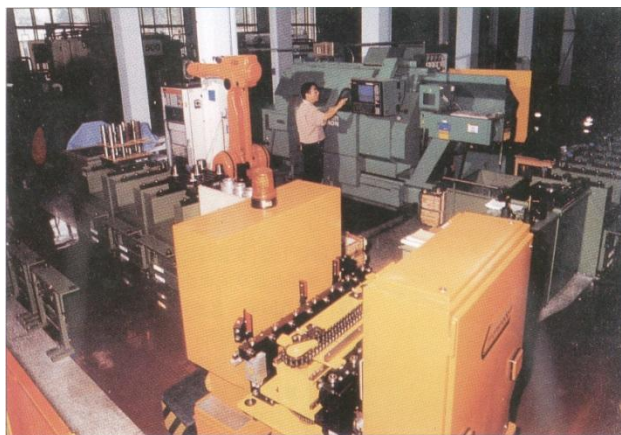

## (9) 第一台火星探测器Sojourner在火星表面软着陆(1996)



## (10) 旅行者Voyager 一号，二号开始走出太阳系，对茫茫太空进行探索

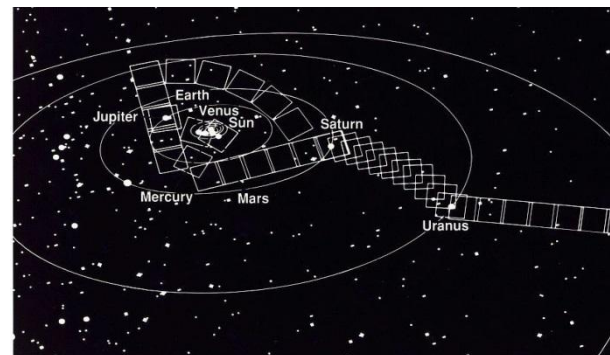
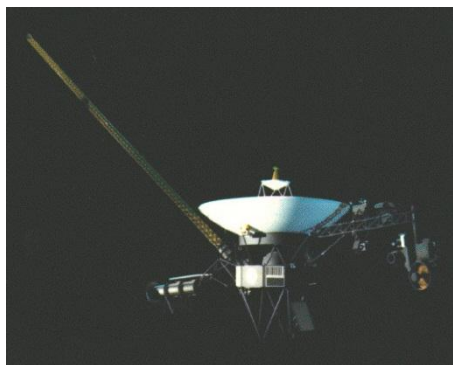

## (11) 火星探测器(勇气号2003)



## (12) 神舟十号载人飞船(2013)



# 智能自动化 (Automation of Intelligence) (2000- )

## (13) BigDog (2008)



## (14) Vijay Kumar 群无人机系统 (2012)



## (15) AlphaGo (2016)

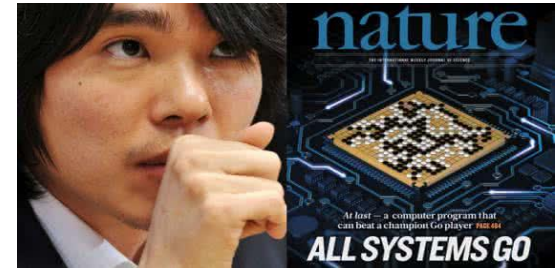

## (16) Deep Reinforcement Learning for Atari 2600 (2015)



## (17) Deep Reinforcement Learning for Mujoco (2016)



## (18) 足式机器人

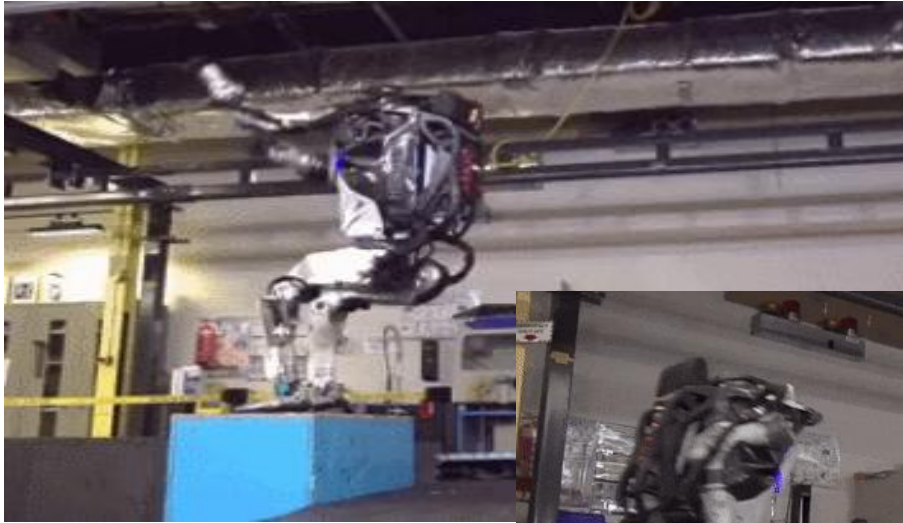

Mini Cheetah is our new 9 kg  
quadruped robot

It's powerful, robust,  
and inexpensive

# (19) 嫦娥四号登录月球背面 (2019年1月3号)

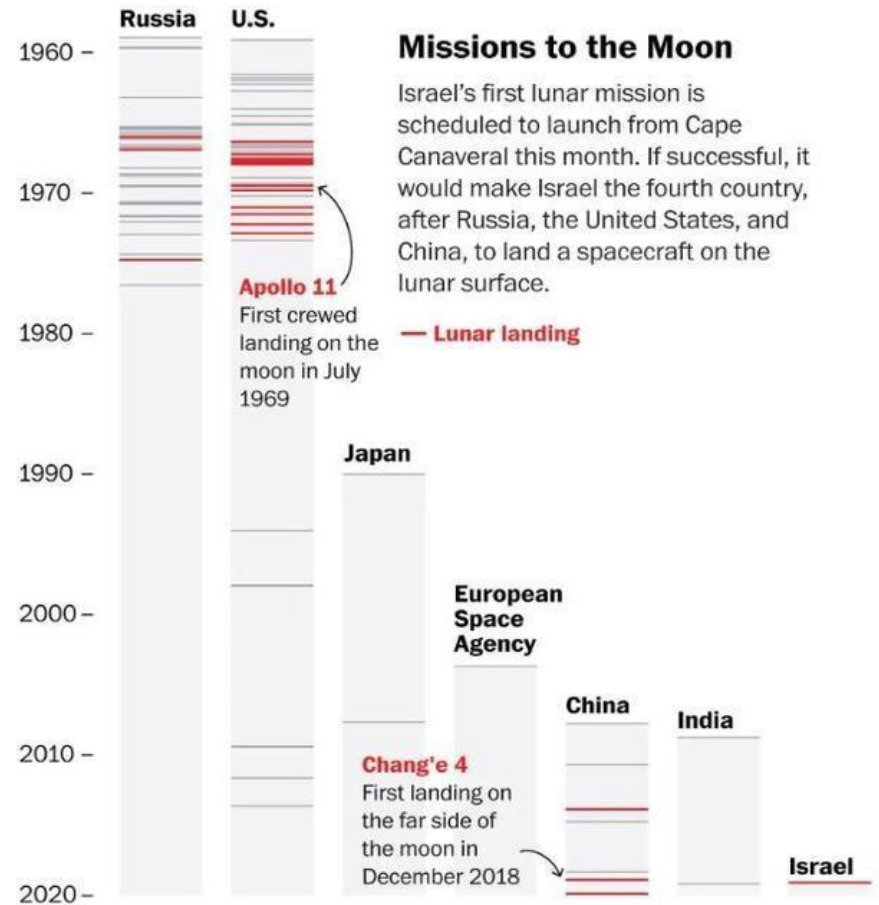
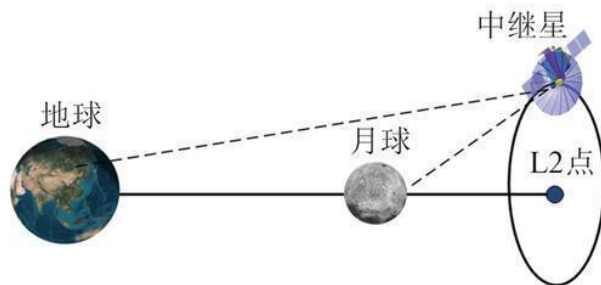
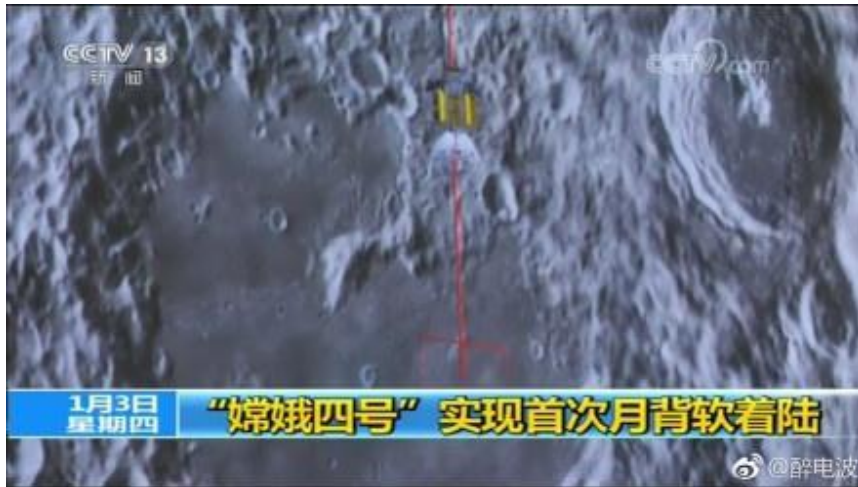

Note: Chart includes three missions that India, Israel and China will send to the Moon later this year

Source: NASA

YOUJIN SHIN/THE WASHINGTON POST

## (20) ANYmal



Random initial configuration



Right front foot makes contact



Shift leg mass



Initial impact



Roll using momentum and retract knees



Final configuration

Jemin Hwangbo et al. Sci. Robotics 2019;4:eaau5872

---

# (21) ChatGPT

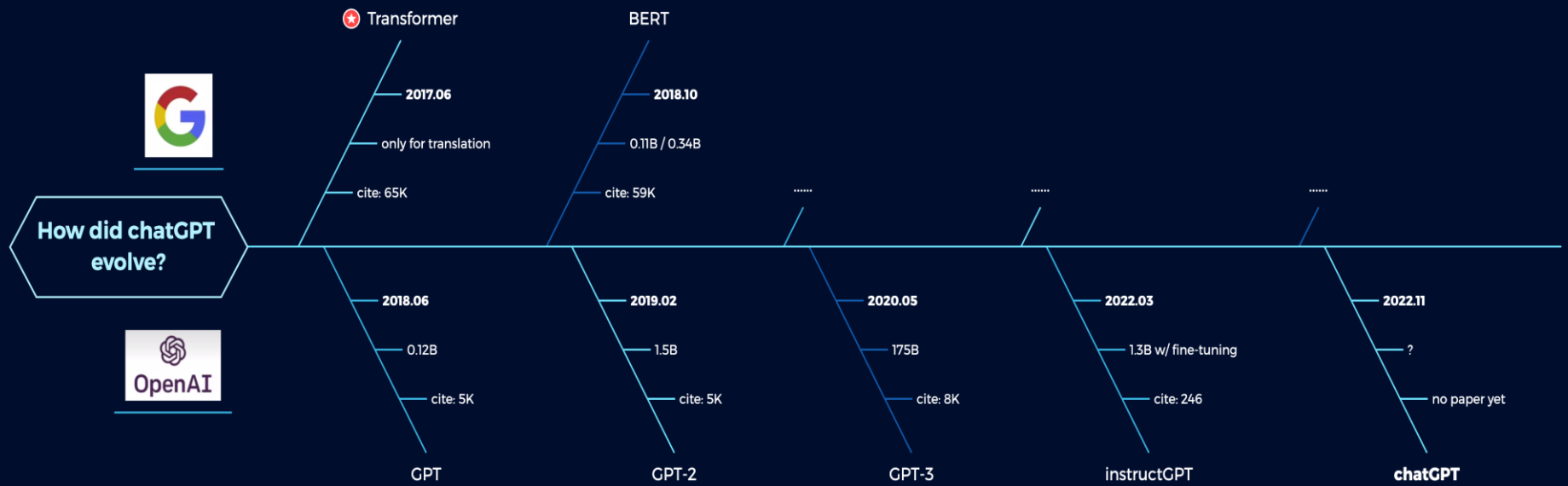

## Robotics today: engineer *in the loop*

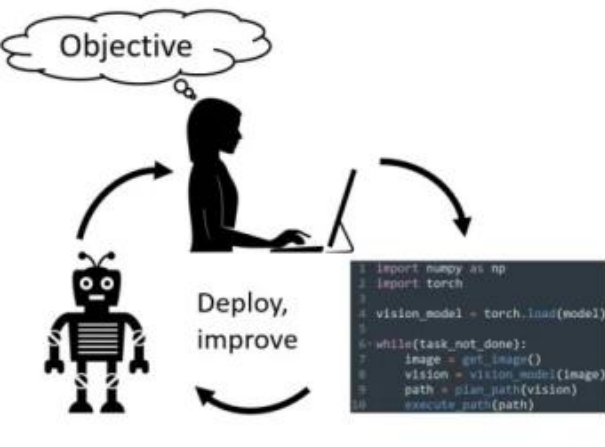

## Goal with ChatGPT: user *on the loop*

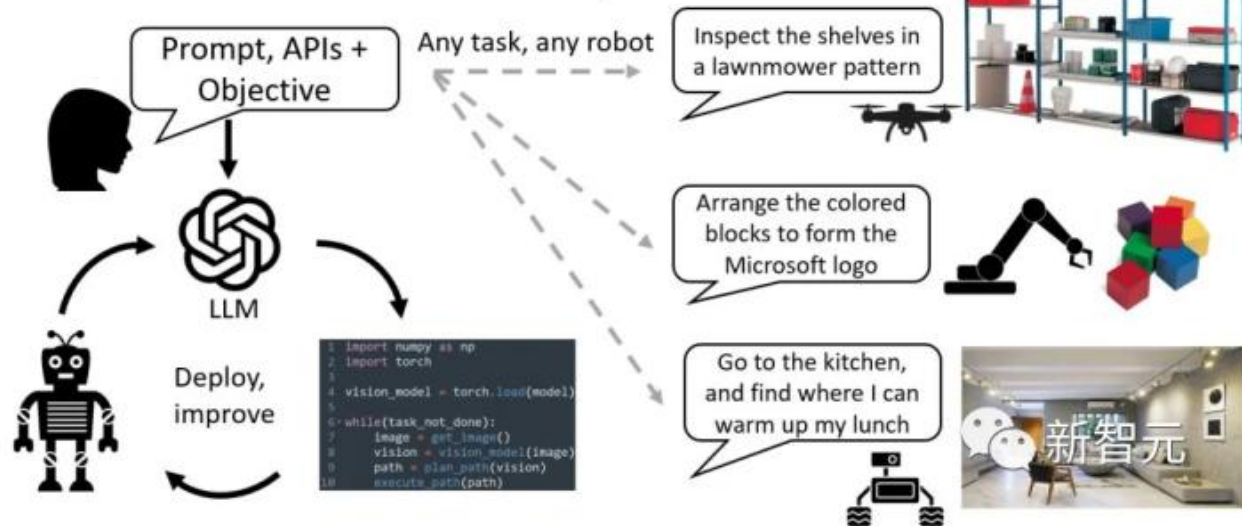

# 小结

- 人类很早以前就进行过自动化的尝试
  - **经典控制(Classical Control)理论**的内容主要以传递函数为基础，研究单输入、单输出一类自动控制系统的设计问题
  - **现代控制(Modern Control)理论**的内容主要以状态空间法为基础，研究多输入、多输出、定常数或变参数、线性或非线性一类自动控制系统的设计问题
  - 随着现代科学技术的发展，又出现了最优控制、最佳滤波、模糊控制、系统辨识、自适应控制、时变系统控制、分布参数系统控制、随机控制等一些新的控制方式。具有向**智能自动化 (Automation of Intelligence)** 方向发展的趋势。
-

# 1.2 自动控制的主要研究领域

- **0811 控制科学与工程**
    - **081101 控制理论与控制工程**
    - **081102 检测技术与自动化装置**
    - **081103 系统工程**
    - **081104 模式识别与智能系统**
    - **081105 导航、制导与控制**
-

## 1.3 一个小例子：倒立摆（Inverted Pendulum）

固高公司的直线一级倒立摆，通过GT400运动控制卡对倒立摆进行控制。整个装置包括伺服机构、倒立摆本体和光电码盘几大部分。

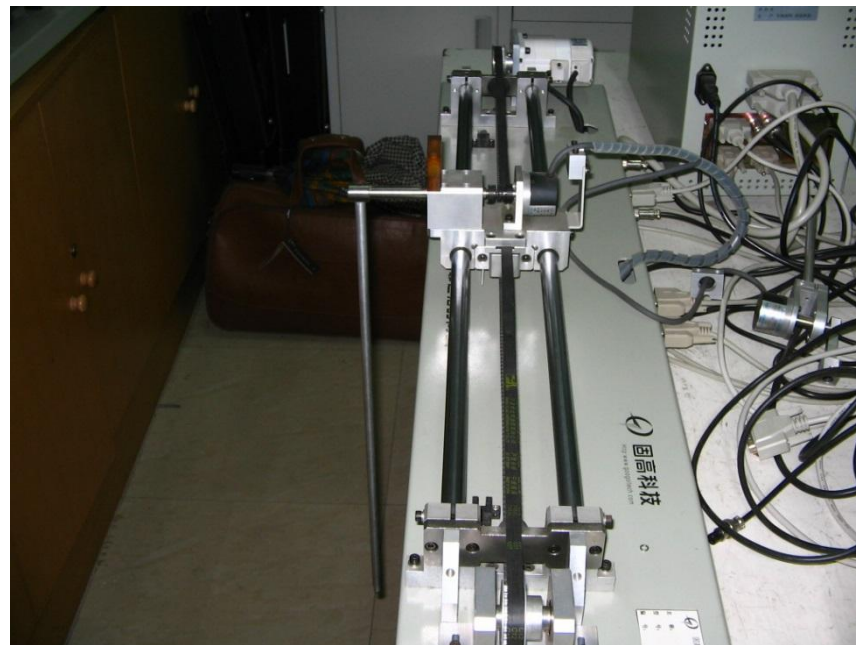
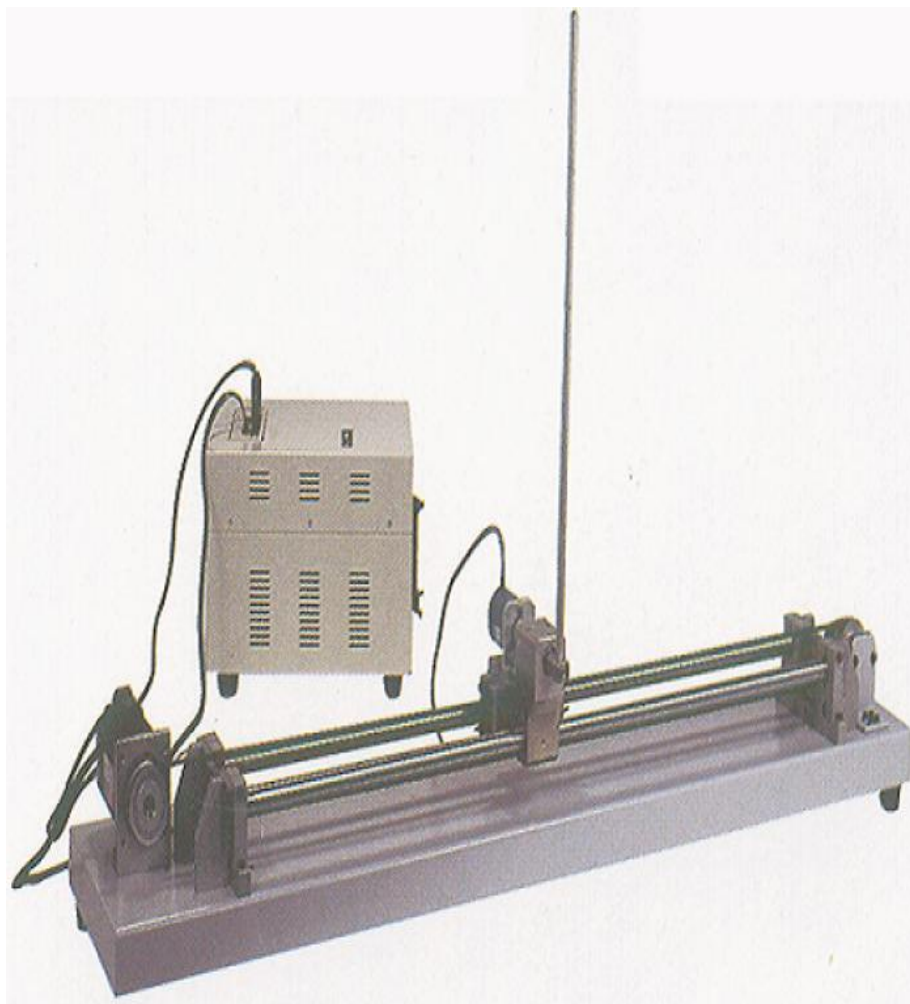

# 一级倒立摆简化模型

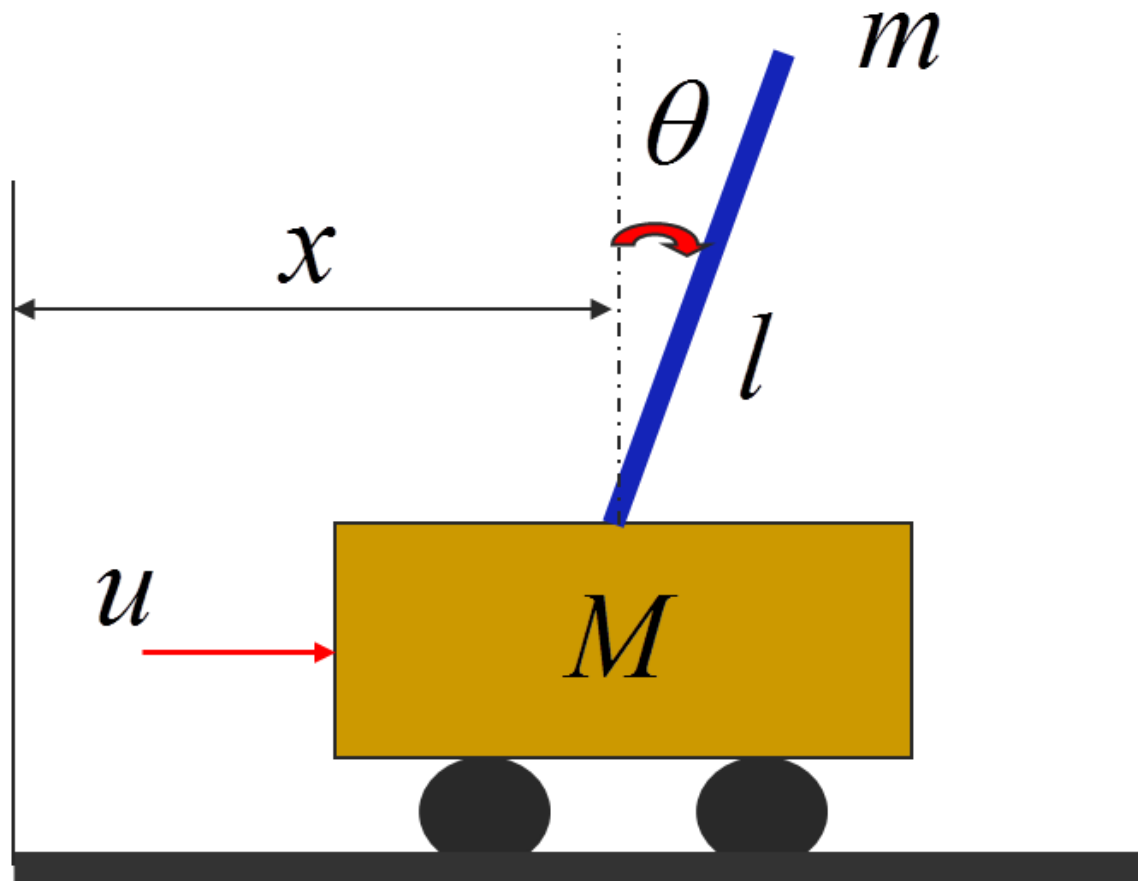





一及倒立摆



二及倒立摆

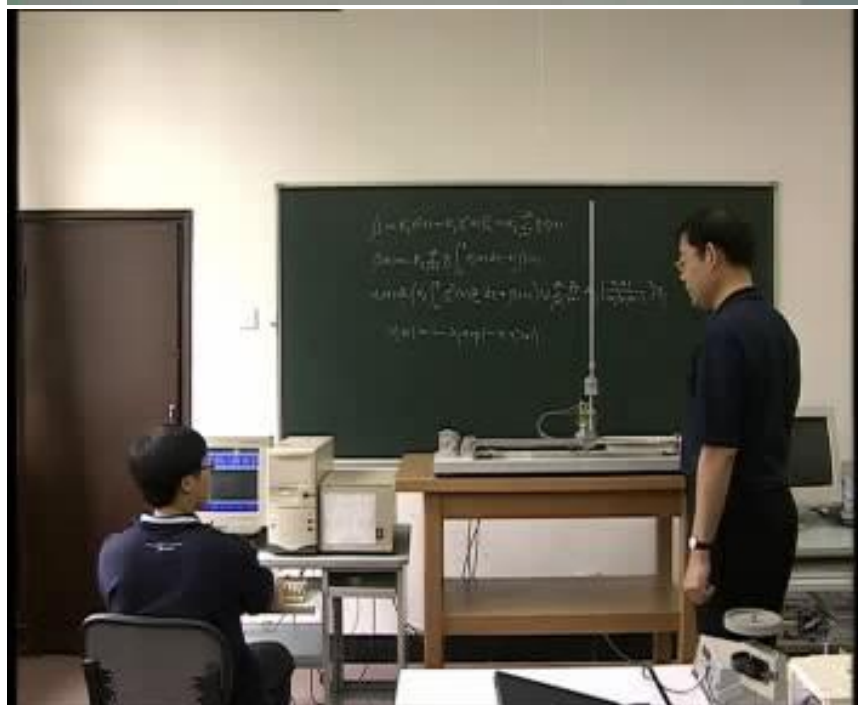

三及倒立摆



四及倒立摆